

Bell's Fabrication Procedures

Square tubing frame.

1. Determine the outside dimension you want to end up with. Refer to Figure 1.
2. Cut the cross pieces two times the material thickness shorter than the desired outside dimension from step one. Make all cuts up to this point square, 45 degree angles will be cut in step three.
3. Once all the pieces are cut square tilt the saw to 45 degrees. With the saw at 45 degrees eyeball the saw blade to be in line with the inside wall of the outer corner.
4. With all the pieces cut there is no grinding required and there is a nice groove for the corner fillet weld.

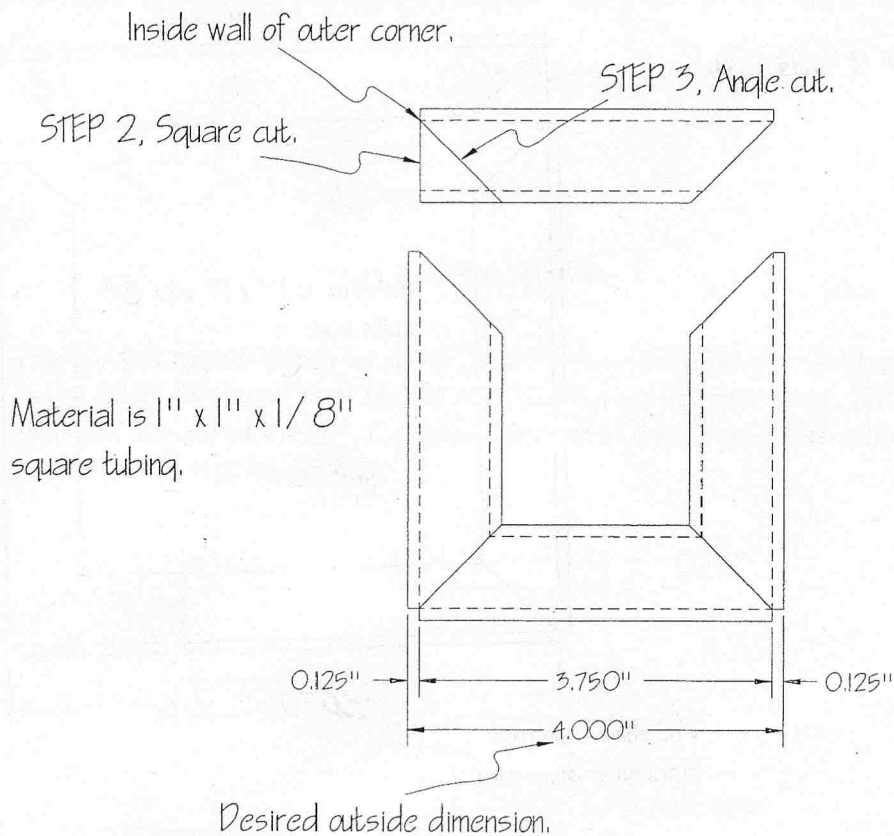

Figure 1. Square tubing corner cutting illustration.

Angle iron frame

With an angle iron frame you are usually fitting something into the frame such as a box or a battery. The following steps show how to accurately make the frame with the proper clearances.

1. Determine the proper clearances you need. For our example in Figure 2 we have an overall clearance of $3/8$ " on a 6" square object ($3/16$ " per side).
2. To find the total length of material to cut add the dimension of the box plus the desired clearance. Cut the four sides of the frame to this length, in our example 6" plus $3/8$ ". Note that we do not need to take into account the web thickness because our required dimension is to the inside of the frame.
3. Tilt the saw 45 degrees and cut the miter being sure to leave the end of the web square as in the previous example.

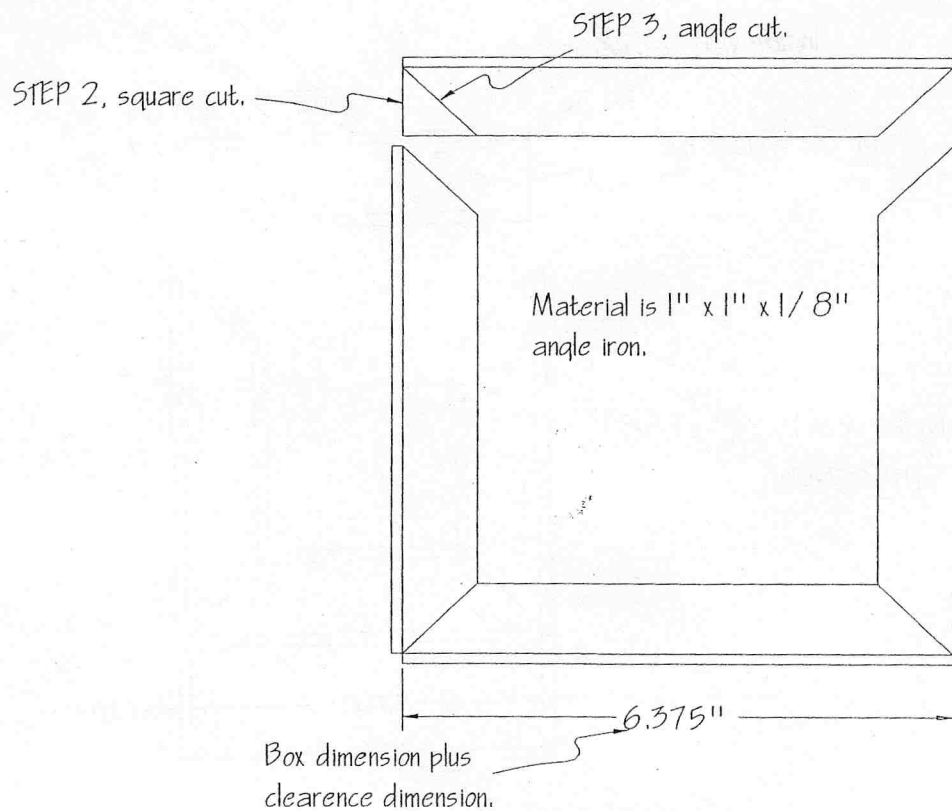

Figure 2. Angle iron frame with clearances.

Fish moutinging

Below is a chart that determines fish mouth depths for round to round tubing and square to round tubing intersections such as those found on tubular chassis. This chart is for intersections with both tubes the equivalent size.

TUBE SIZE O.D.	FISH MOUTH DEPTH
1/2"	0.125
3/4"	0.187
1"	0.25
1 1/4"	0.312
1 1/2"	0.375
2"	0.5

The table is simply calculated. The depth of the fish mouth is half of the tubing radius or a quarter of the tubing diameter. So any size tubing fish mouth depth can be calculated. Keep in mind that the cutter used to fish mouth must be the same diameter as the tubing.

Example:

We have two tubes four inches apart, inside to inside, as shown in the drawing. The tubing is .875" O.D. We need to span the two tubes with a tube of the same material.

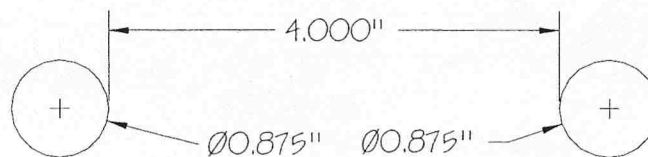

Figure 3. Tubing problem.

First calculate the fish mouth depth by dividing .875 by 4 (remember: one quarter the diameter) to get .218". We need four inches of tube to make the span plus .218" of fish mouth on each end, a total of 4.436". Cut your material to this length, fish mouth it to the proper depth and the fit will be perfect.

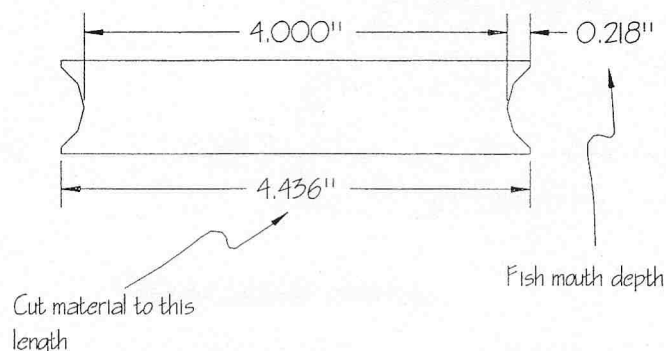

Figure 4. Tubing problem, fish mouth depth and tubing length.